

HDXT Load Insert



Application

HDXT load inserts are designed to be used with the Kwik-ZIP HDXT casing spacers to provide additional load capacity for very heavy applications or where high point loadings on one runner are experienced.

They also allow HDXT spacers to continue to carry heavy loads at elevated temperatures.

Construction & Features

- Load Inserts made from Kwik-ZIPs engineered thermoplastic blend with high flexural strength, high-temperature resistance and outstanding chemical resistance.
- When used in conjunction with HDXT casing spacers will increase load capacity up to 1000kg per runner.
- Unique load sharing characteristics of Kwik-Zip spacers allow multiple load inserts to be used for optimum effect.
- Particularly useful for slip lining applications where large differences between casing pipe radius and enveloper radius exist causing point loadings
- No special installation tools are required. Load inserts can be installed on site.
- HDXT Load Inserts can be used in either in every runner, or just in the centre and outer runners on each HDXT segment, depending on load requirements.

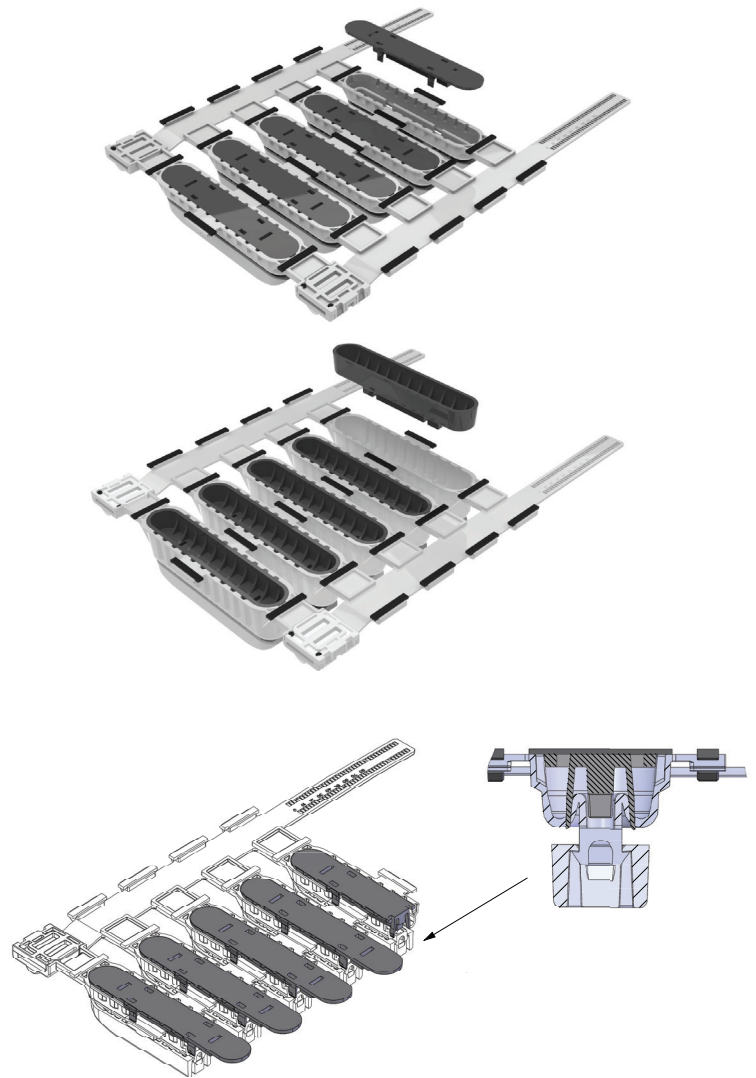

Models

Model	Matching HDXT model	Part #	Operating Temp	Units per Carton	Carton Dimensions	Gross Carton Weight
LI-XT 43	HDXT-43/ HDXT-58W	00003	-20 C to 80 C -4 F to 176 F	100	15.0 x 13.4 x 4.7" 380 x 340 x 120mm	7.9 lbs / 3.6 Kg
LI XT-63	HDXT-63/ HDXT-78W	00005		100	15.3 x 14.6 x 6.3" 390 x 370 x 160mm	14.8 lbs / 6.7 Kg
LI XT-103	HDXT-103	00007		100	16.5 x 15.7 x 11.8" 420 x 400 x 300mm	30.6 lbs / 13.9 Kg
LI XT-153	HDXT-153	00009		100	19.3 x 16.5 x 14.2" 490 x 420 x 360mm	49.4 lbs / 22.4 Kg

Compliance

- Manufactured under a certified ISO 9001 Quality Management System.
- Compliant with WSAA Product Specification # 324 – Casing Spacer.

