

## Application

A non-metallic roller assembly designed to be used with Kwik-ZIP HDXT-58W and HDXT-78W casing spacer models to provide an alternative spacer solution to long-run slip lining installations where the reduction of any sliding friction is critical.

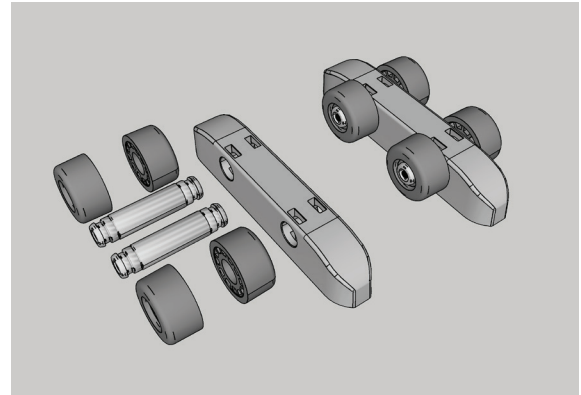

## Construction & Features

- Roller body and wheels made from Kwik-ZIPs engineered thermoplastic blend with high flexural strength, high-temperature resistance and outstanding chemical resistance. Wheels axles are ultra-low friction reinforced axles.
- Limited moving parts produce an overall coefficient of friction of approx 0.065 which minimizes insertion forces.
- Roller assembly is installed through the specially modified wear pad.
- Unique load sharing characteristics of Kwik-Zip spacers are unaffected allowing load to be distributed across multiple roller assemblies, minimizing point loading and increasing capacity overall.
- No special installation tools required. The axles are simply installed through the modified wear pad, and the wheels clipped on either end.

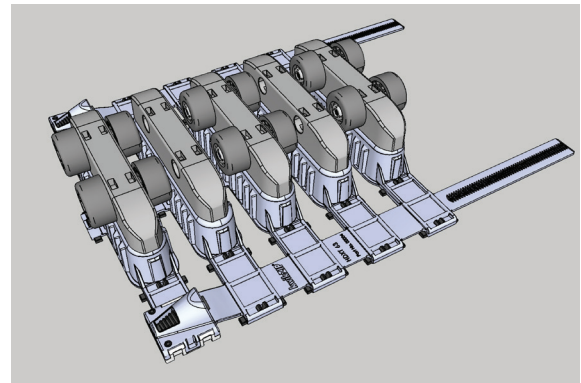
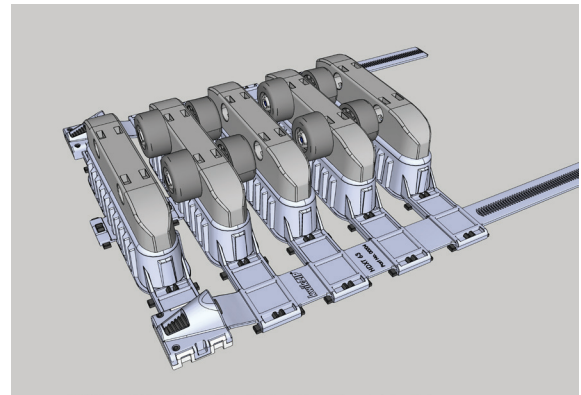

## Models

Model	Equivalent Runner Height	Part #	Operating Temp (Deg C / F)	Recommended for use on Pipe Diameter	Units per Carton	Carton Dimensions (L x W x H)	Gross Carton Weight
Kwik-Roller® with HDXT -58W	58mm (without kwik-ROLLER® wheels) 65mm (inclusive of kwik-ROLLER® wheels)	00015	-20 C to 80 C	Unlimited	100 (1 unit = two axles and 4 wheels)	350 x 315 x 230mm 13.8 x 12.4 x 9.1"	12 kg / 26.45 lbs
Kwik-Roller® with HDXT -78W	78mm (without kwik-ROLLER® wheels) 85mm (inclusive of kwik-ROLLER® wheels)		-4 F to 176 F				

## Compliance

- Manufactured under a certified ISO 9001 Quality Management System